

# FITTING INSTRUCTIONS

**WARNING:** Installing brake pads into brake caliper can be dangerous to vehicle safety if not correctly fitted by suitably trained mechanic. It is important to understand and follow the fitting instructions. If in doubt or difficulty, seek professional help. It is important to replace pads in axle sets.

**PRECAUTIONS** before dismantling: Comply with safety instructions. Work in properly ventilated premises. Do not use compressed air to clean the brake dusts. Avoid inhaling brake dusts that can be dangerous to health. Whenever possible, use vacuum brush or cloth damp with water to wipe and dispose off cloth safely.

1. Remove the brake fluid reservoir cap, and apply firm force when pushing the pistons back, to ensure no overflow of brake fluid.
2. Work on one wheel at a time.
3. Chock the wheels.
4. Jack up the appropriate end of the vehicle and securely fit axle stands.
5. Remove the wheels and note the positions of the pads, shims and clips.
6. Do not apply the brakes whilst working on them.
7. Wipe and clean the dusty parts and check for any brake fluid leaks at the seal cover.

**PRECAUTIONS** after assembly.

8. Top up the brake fluid reservoir as appropriate and close the cap.
9. Operate the brake pedal several times to move the pads to operating position.
10. For optimum efficiency new pads must be bedded in to the rotor surface.
11. Avoid repeated hard braking immediately after fitting the new pads.

## Depending on the caliper type:

### DISMANTLING

Withdraw split pins / or unscrew bolt to lift the caliper cover.

Remove the pads.  
Remove the shims.

### ASSEMBLY

1. Wipe the caliper clean.
2. Push back the pistons firmly.
3. Fit the squeal shims to the pad / or position correctly in the caliper.
4. Slot the pads into the caliper, ensure firm fitting with the appropriate clips and springs.
5. Fully push home both split pins.
6. Lower the caliper cover to hold the pads to the rotor firmly and tighten the bolt.

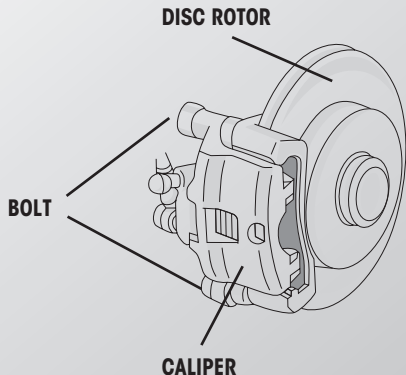
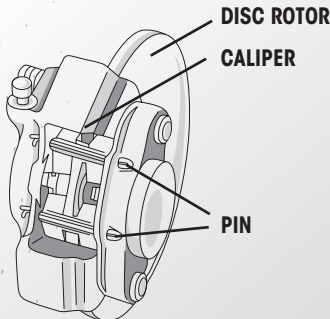

ORIGINAL BRAND

PFK166

# Warranty Statement

All products sold by FBK Manufacturing (formerly known as DJACM) are warranted for a period of 12 months or 12,000 Kilometers from the date of fitment, whichever should come first. The warranty covers any defect in materials or workmanship only. Warranty is for replacement or refund of purchase value only, excludes all labour, consequential damages and ancillary charges such as but not limited to: vehicle towing, fitting, inconvenience, purchasing of other manufacturers products.

**The FBK Warranty does not cover the use of the motor vehicle for:**

- (1) Any kind of Motor Sport
- (2) Modified Vehicles
- (3) Private hire or Taxi.

FBK reserves the right to recharge Customers transport & handling costs incurred in considering parts returned which are subsequently found to be not of FBK origin. The FBK warranty applies to product that has been fitted in accordance with FBK guidelines detailed in fitting instructions. FBK is not responsible for reduced service life or failure resulting from fair wear and tear, willful damage, negligence, abnormal working conditions, failure to follow the manufacturer's instructions (installation or otherwise, and, whether oral or in writing), incorrect storage or operation misuse or alteration or modification or repair of the Goods or overload of vehicle, vehicle accident or additional tests are carried out by the Customer or a third party on its behalf without the Company's approval. FBK is not responsible for downtime, loss of income, living expenses, or other incidental or consequential damages. In order for a warranty claim to be processed for a replacement product or credit to be issued, an FBK returns form must be completed and approved by FBK.

**For feedback and enquiries Please visit: [www.fbk.my/feedback](http://www.fbk.my/feedback)**

Aftermarket Warranty Statement, Issue 1: V2 DATE: May 2019